

**digital**

**BD -50**

**Engineering Drawings**

**Digital Equipment Corporation**

The material herein is for information purposes only and is subject to change without notice. Digital Equipment Corporation assumes no responsibility for any errors which may appear herein.

These drawings and specifications herein are the property of Digital Equipment Corporation and shall not be reproduced or copied or used in whole or in part as the basis for the manufacture or sale of items without written permission.

Copyright © 1975, Digital Equipment Corporation



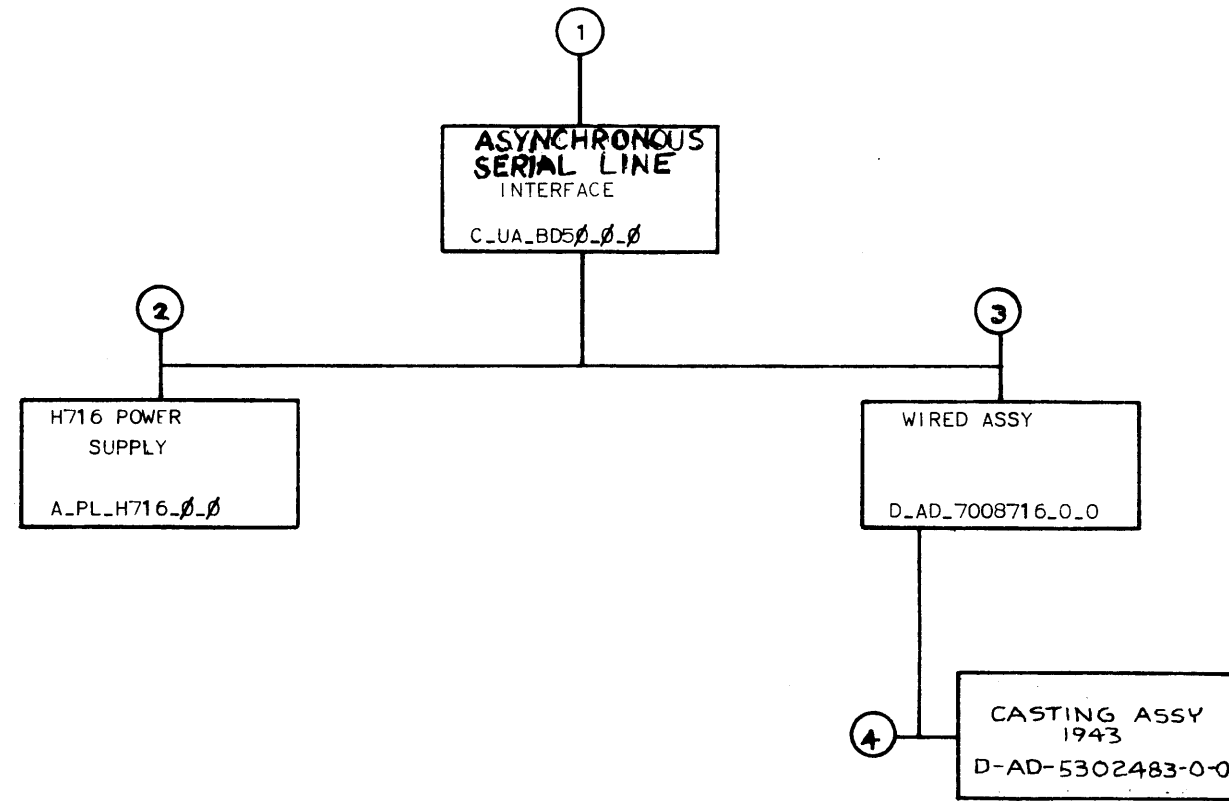

TITLE	SHEET 2 OF 3	SIZE CODE	NUMBER	REV
ASYNCHRONOUS SERIAL LINE INTERFACE		B DD	BD5φ-φ	E



This drawing and specifications, herein, are the property of Digital Equipment Corporation and shall not be reproduced or copied or used in whole or in part as the basis for the manufacture or sale of items without written permission.

USAGE	1	2	3	4	5	6	7	8	9	10	11	12	13	14	15	16	17	18	19	20	21	22	
	M912	M912	M912	M912	M983	M983	M983	M983	M983	M983	M500	M500	M500	M821	M401	M706	M707	CABLE	M401	M401	M706	M707	
	1/0 CABLE	1/0 CABLE	1/0 CABLE	1/0 CABLE	1/0 CABLE	1/0 CABLE	1/0 CABLE	1/0 CABLE	1/0 CABLE	1/0 CABLE	CONVERTER	CONVERTER	CONVERTER	CHO SEL	REC CLK	REC CLK	TRANS. CH1	TO TERM	TR CLK	REC CLK	REC CLK	TRANS. CH1	
D	10 SYNC IOP1 IOP2 IOP4	DS 8 THRU 95	1/0 BUS 85 THRU 98	1/0 BUS 85 THRU 98	10 SYNC IOP1 IOP2 IOP4	DS 8 THRU 95	1/0 BUS 85 THRU 98	1/0 BUS 85 THRU 98	10 SYNC IOP1 IOP2 IOP4	DS 8 THRU 95	1/0 BUS 85 THRU 98	1/0 BUS 85 THRU 98	10 SYNC IOP1 IOP2 IOP4	DS 8 THRU 95	1/0 BUS 85 THRU 98	1/0 BUS 85 THRU 98	10 SYNC IOP1 IOP2 IOP4	DS 8 THRU 95	1/0 BUS 85 THRU 98	1/0 BUS 85 THRU 98	10 SYNC IOP1 IOP2 IOP4	DS 8 THRU 95	1/0 BUS 85 THRU 98
A	1/0 BUS 85 THRU 98	1/0 BUS 85 THRU 98	1/0 BUS 85 THRU 98	1/0 BUS 85 THRU 98	1/0 BUS 85 THRU 98	1/0 BUS 85 THRU 98	1/0 BUS 85 THRU 98	1/0 BUS 85 THRU 98	1/0 BUS 85 THRU 98	1/0 BUS 85 THRU 98	1/0 BUS 85 THRU 98	1/0 BUS 85 THRU 98	1/0 BUS 85 THRU 98	1/0 BUS 85 THRU 98	1/0 BUS 85 THRU 98	1/0 BUS 85 THRU 98	1/0 BUS 85 THRU 98	1/0 BUS 85 THRU 98	1/0 BUS 85 THRU 98	1/0 BUS 85 THRU 98	1/0 BUS 85 THRU 98	1/0 BUS 85 THRU 98	

USAGE	23	24	25	26	27	28	29	30	31	32	33	34	35	36	37	38	39	40	41	42	43	44
	M112	M112	M112	M112	M112	M112	M112	M112	M112	M112	M112	M112	M112	M112	M112	M112	M112	M112	M112	M112	M112	M112
	1/0 CABLE	1/0 CABLE	1/0 CABLE	1/0 CABLE	1/0 CABLE	1/0 CABLE	1/0 CABLE	1/0 CABLE	1/0 CABLE	1/0 CABLE	1/0 CABLE	1/0 CABLE	1/0 CABLE	1/0 CABLE	1/0 CABLE	1/0 CABLE	1/0 CABLE	1/0 CABLE	1/0 CABLE	1/0 CABLE	1/0 CABLE	1/0 CABLE
B	10 RUN	10 ADDR 89	NR RQ	AP12 RQ GR	10 RUN	10 ADDR 89	NR RQ	AP12 RQ GR	10 RUN	10 ADDR 89	NR RQ	AP12 RQ GR	10 RUN	10 ADDR 89	NR RQ	AP12 RQ GR	10 RUN	10 ADDR 89	NR RQ	AP12 RQ GR	10 RUN	10 ADDR 89
C	DATA OFLO	10 OFLO	10 ADDR 83	10 ADDR 89	10 OFLO	10 ADDR 83	10 ADDR 89	10 OFLO	10 ADDR 83	10 ADDR 89	10 OFLO	10 ADDR 83	10 ADDR 89	10 OFLO	10 ADDR 83	10 ADDR 89	10 OFLO	10 ADDR 83	10 ADDR 89	10 OFLO	10 ADDR 83	10 ADDR 89

USAGE	45	46	47	48	49	50	51	52	53	54	55	56	57	58	59	60	61	62	63	64	65	66
	M115	M115	M115	M115	M115	M115	M115	M115	M115	M115	M115	M115	M115	M115	M115	M115	M115	M115	M115	M115	M115	M115
	1/0 CABLE	1/0 CABLE	1/0 CABLE	1/0 CABLE	1/0 CABLE	1/0 CABLE	1/0 CABLE	1/0 CABLE	1/0 CABLE	1/0 CABLE	1/0 CABLE	1/0 CABLE	1/0 CABLE	1/0 CABLE	1/0 CABLE	1/0 CABLE	1/0 CABLE	1/0 CABLE	1/0 CABLE	1/0 CABLE	1/0 CABLE	1/0 CABLE
D	SEL 89	AREQ (1)H	SEL 89	AREQ (1)H	SEL 89	AREQ (1)H	SEL 89	AREQ (1)H	SEL 89	AREQ (1)H	SEL 89	AREQ (1)H	SEL 89	AREQ (1)H	SEL 89	AREQ (1)H	SEL 89	AREQ (1)H	SEL 89	AREQ (1)H	SEL 89	AREQ (1)H
A	SEL 89	AREQ (1)H	SEL 89	AREQ (1)H	SEL 89	AREQ (1)H	SEL 89	AREQ (1)H	SEL 89	AREQ (1)H	SEL 89	AREQ (1)H	SEL 89	AREQ (1)H	SEL 89	AREQ (1)H	SEL 89	AREQ (1)H	SEL 89	AREQ (1)H	SEL 89	AREQ (1)H

REV.	CHG.	NO.	DATE	BY
1	BD50-00001	A	1-21-72	LEARSON
2	BD50-00002	B	1-22-72	LEARSON

▲ 8 FAMILY NEG BUS CABLES BC88C-6  
 \* 8 FAMILY POS BUS CABLES BC88A-6  
 ● WHEN USED ON PDP-9 REMOVE M500 FROM A13 AND PUT IN A12  
 ○ ONLY USED WITH PDP-9  
 □ BC88C-5, PDP-9

FIRST USED ON OPTION/MODEL  
 BD50

DO NOT SCALE DRAWING	DRN. <i>CEM</i>	DATE 1-21-72	
UNLESS OTHERWISE SPECIFIED DIMENSION IN INCHES	CHK'D. <i>...</i>	DATE 1-22-72	
TOLERANCES	ENG. <i>...</i>	DATE 1-22-72	TITLE
DECIMALS FRACTIONS ANGLES	PROJ. ENG. <i>...</i>	DATE 1-22-72	MODULE UTILIZATION
± .005 = 1/64 = 0°30'	PROD. <i>...</i>	DATE 1-22-72	BD50
FINAL SURFACE QUALITY REMOVE BURRS AND BREAK SHARP CORNERS	NEXT HIGHER ASSY		
MATERIAL	B-DD-BD50-0		
FINISH	SCALE		
	SHEET 1 OF 1		

SIZE CODE NUMBER  
 BD50-0-1  
 REV. B



This drawing and specifications herein, are the property of Digital Equipment Corporation and shall not be reproduced or copied in whole or in part as the basis for the manufacture or sale of items without written permission.  
 1972

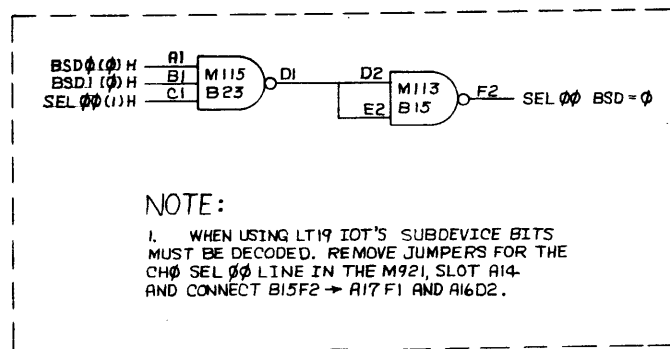
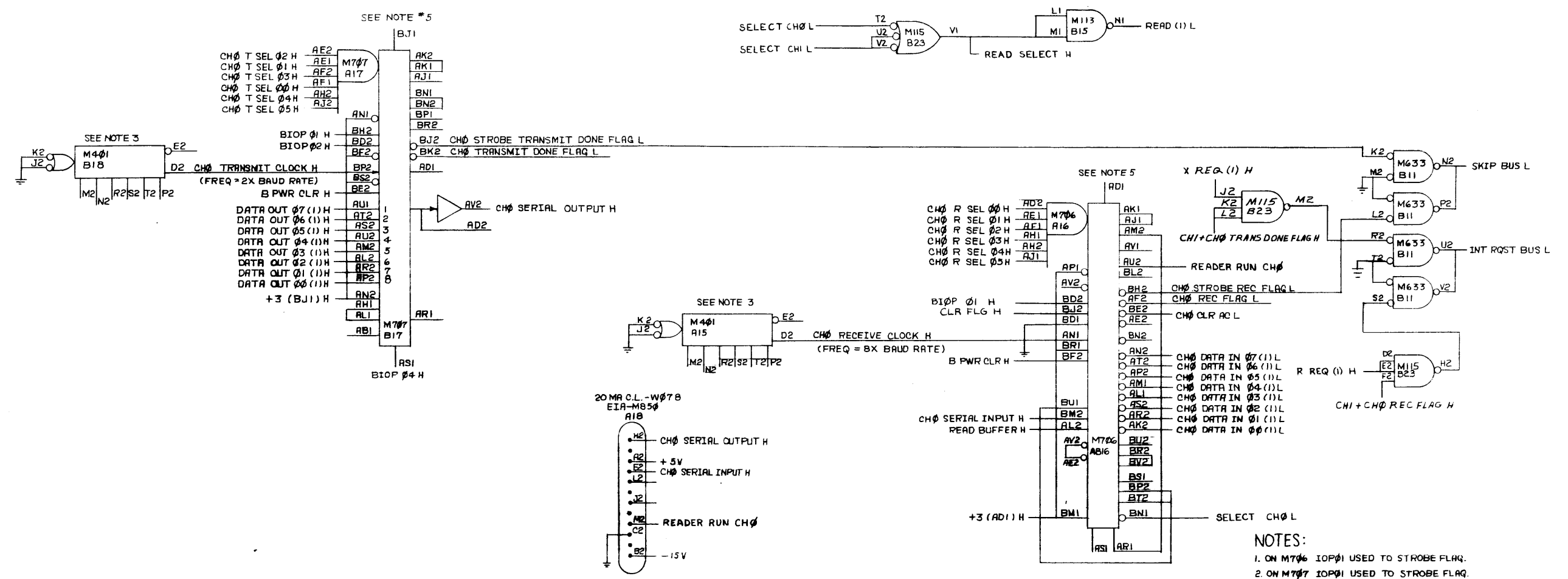

**NOTE:**  
 1. WHEN USING LT19 IOT'S SUBDEVICE BITS MUST BE DECODED. REMOVE JUMPERS FOR THE CH0 SEL 00 LINE IN THE M921, SLOT A14 AND CONNECT B15F2 → A17F1 AND A16D2.

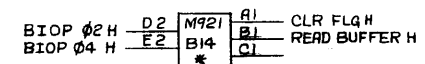

\* WHEN USED ON PDP-8, B1, B1, B5 CONNECT JUMPERS B14D2 → B14A1 AND B14E2 → B14B1.  
 WHEN USED ON PDP-9 CONNECT JUMPERS B14D2 → B14A1 AND B14B1.

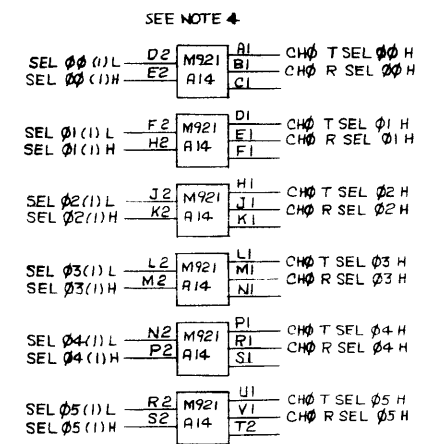

- NOTES:**
- ON M706 IOP01 USED TO STROBE FLAG.
  - ON M707 IOP01 USED TO STROBE FLAG. IOP02 USED TO CLEAR FLAG. IOP04 USED TO LOAD DATA BUFFER (WRITE)
  - ON M401 SEE BELOW FOR DESIRED FREQUENCY.
  - FOR JUMPER CONNECTION SEE PRINT (BD50-0-06)
  - WHEN USED WITH LA30 REMOVE M706, M707 AND M401'S AND REPLACE WITH M7718 AND M7719 RESPECTIVELY.
  - WHEN USED AS A SINGLE CHANNEL UNIT JUMPER CHI FLAGS TO B15 U1.

FREQUENCY RANGE	INTERCONNECTION REQUIRED
1.5MHZ TO 10MHZ	(100 pf) NONE
175KHZ TO 1.75MHZ	(1000 pf) N2 TO R2
17.5KHZ TO 175KHZ	(.01 ufd) N2 TO S2
1.75KHZ TO 17.5KHZ	(0.1 ufd) N2 TO T2
175HZ TO 1.75KHZ	(1.0 ufd) N2 TO P2

FIRST USED ON OPTION/MODEL	QTY.	DESCRIPTION	PART NO.	ITEM NO.
PDP-8		PARTS LIST		
UNLESS OTHERWISE SPECIFIED DIMENSION IN INCHES. TOLERANCES	DRN <i>[Signature]</i> DATE 11-10-71	digital EQUIPMENT CORPORATION MAYNARD MASSACHUSETTS TITLE CH0 XMTR & RECEIVER		
DECIMALS	CHK'D <i>[Signature]</i> DATE 1-26-72			
ANGLES	ENG. <i>[Signature]</i> DATE 1-26-72			
XXX - .005 XX - .02 X - .1	PROJ. ENG. <i>[Signature]</i> DATE 1-26-72			
MATERIAL	PROD. <i>[Signature]</i> DATE 1-26-72	REMOVE BURRS AND BREAK SHARP CORNERS SURFACE QUALITY		
FINISH				

REV.	CHG. NO.	REV.
A	ED50-00001	A
B	BD50-00003	B
C	BD50-00005	C

This drawing and specifications, herein, are the property of Digital Equipment Corporation and shall not be reproduced or copied or used in whole or in part as the basis for the manufacture or sale of items without written permission.

BS B50-0-03 2

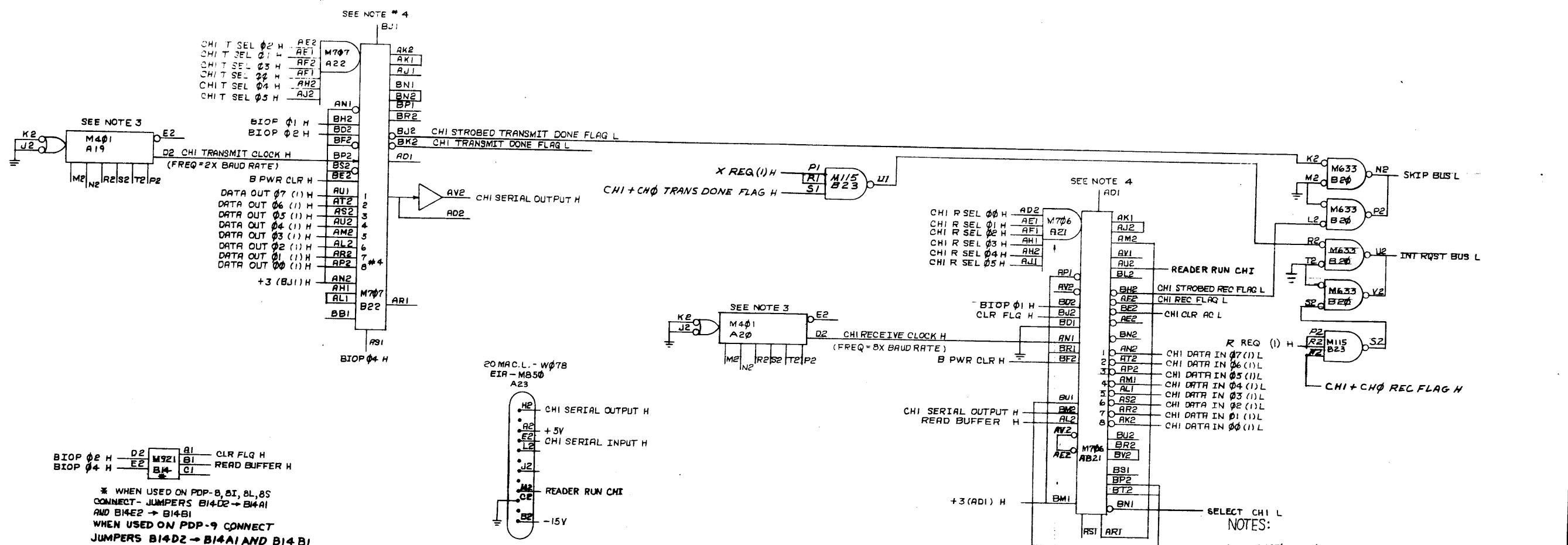

BIOP  $\phi 2$  H D2 M921 A1 CLR FLG H  
 BIOP  $\phi 4$  H E2 M921 B1 READ BUFFER H  
 BIOP  $\phi 4$  H E2 M921 C1

\* WHEN USED ON PDP-8, 8I, 8L, 8S  
 CONNECT - JUMPERS B14D2  $\rightarrow$  B14A1  
 AND B14E2  $\rightarrow$  B14B1  
 WHEN USED ON PDP-9 CONNECT  
 JUMPERS B14D2  $\rightarrow$  B14A1 AND B14B1

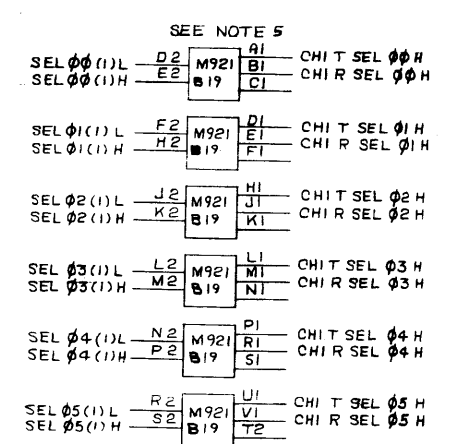
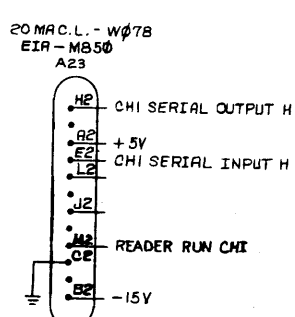

NOTE:

1. WHEN USING LT19 IOT'S, SUB DEVICE BITS MUST BE DECODED. REMOVE JUMPERS FOR THE CHI SEL  $\phi 0$  LINE IN THE M921 SLCT B19 AND CONNECT B15K2  $\rightarrow$  A22F1 AND A21D2

- NOTES:
- ON M706 IOP $\phi 1$  USED TO STROBE FLAG
  - ON M707 IOP $\phi 1$  USED TO STROBE FLAG IOP $\phi 2$  USED TO CLEAR FLAG IOP $\phi 4$  USED TO LOAD DATA BUFFER (WRITE).
  - ON M401 SEE BELOW FOR CONNECTING DESIRED FREQUENCY
  - WHEN USED WITH L430 REMOVE M706, M707 AND M401'S AND REPLACE WITH M7718 AND M7709 RESPECTIVELY
  - FOR JUMPER CONNECTION SEE PRINT (B050-0-06)

FREQUENCY RANGE	INTERCONNECTION REQUIRED
1.5MHZ TO 10MHZ	(100 pf) NONE
17.5 KHZ TO 173 KHZ	(1000 pf) N2 TO R2
17.5 KHZ TO 175 KHZ	(.01 $\mu$ f) N2 TO S2
1.75 KHZ TO 17.5 KHZ	(.1 $\mu$ f) N2 TO T2
175HZ TO 1.75 KHZ	(1.0 $\mu$ f) N2 TO P2

REVISIONS

REV	CHANGE NO.	REV
A	BD50-00001	11-17-72
B	BD50-00003	1-15-73
C	BD50-00004	9-15-72
D	BD50-00005	12-15-72

FIRST USED ON OPTION/MODEL	QTY.	DESCRIPTION	PART NO.	ITEM NO.
PDP-8				
UNLESS OTHERWISE SPECIFIED DIMENSION IN INCHES. TOLERANCES				
DECIMALS	ANGLES	DATE		
.xxx = .006	$\pm 0^{\circ} 30'$	DRN. <i>Margaret Kump</i>	DATE	11-4-71
.xx = .02		CHK'D. <i>J. J. ...</i>	DATE	1-26-72
.x = .1		ENG. <i>J. J. ...</i>	DATE	1-26-72
REMOVE BURRS AND BREAK SHARP CORNERS SURFACE QUALITY				
MATERIAL				
NEXT HIGHER ASSY.				
FINISH				
SCALE				
SHEET OF				
PARTS LIST				
digital EQUIPMENT CORPORATION MAYNARD, MASSACHUSETTS				
TITLE CHI XMT&R RECEIVER				
SIZE CODE NUMBER REV. B-DD-B050-1-03 D				
DIST.				



This drawing and specifications, herein, are the property of Digital Equipment Corporation and shall not be reproduced or copied or used in whole or in part as the basis for the manufacture or sale of items without written permission.

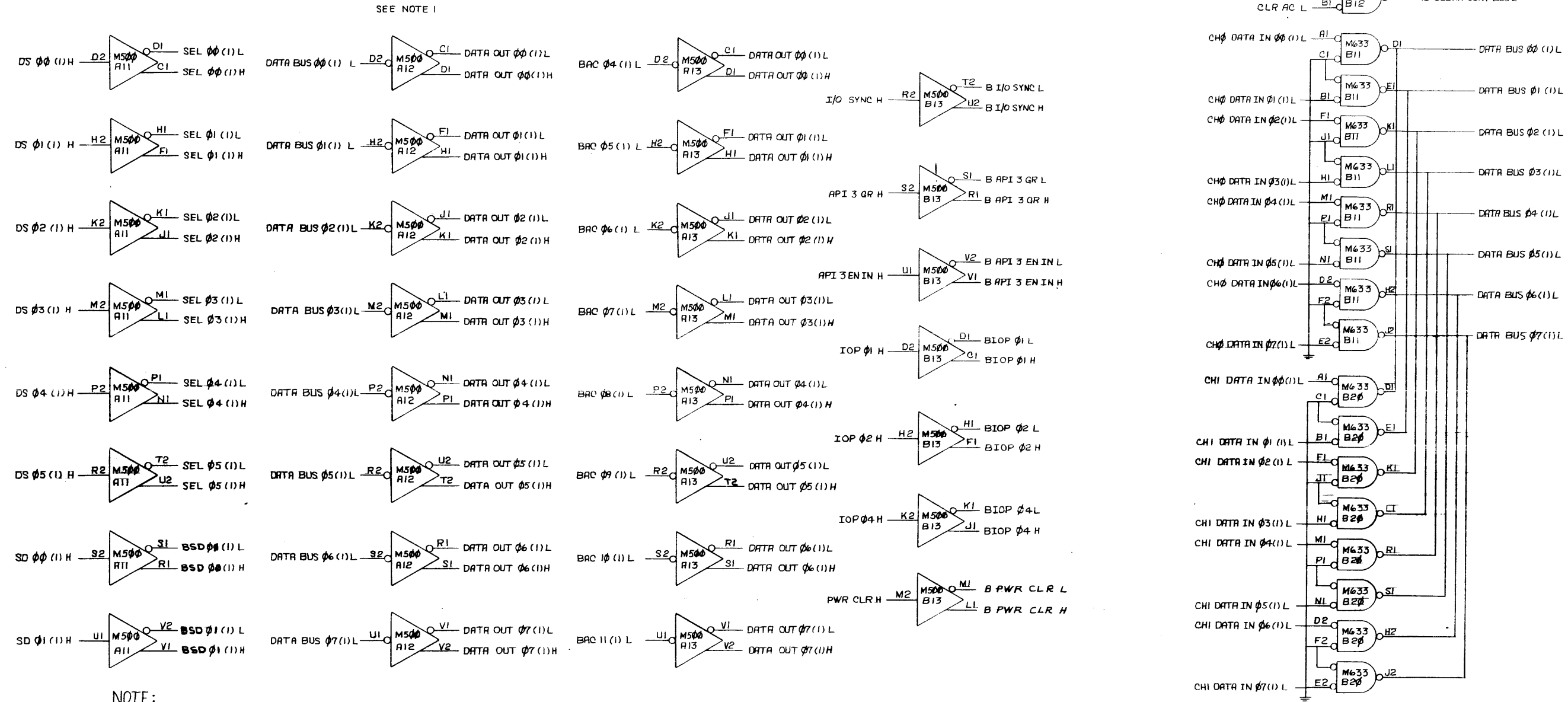

SEE NOTE 1

NOTE:  
 1. WHEN USED ON A PDP-9 REMOVE M500 FROM SLOT A13 AND INSERT IT IN SLOT A12.  
 2. WHEN USED ON POS BUS COMPUTER REMOVE ALL M500'S AND REPLACE M633'S WITH M623'S.

REV.	CHG.	NO.	DATE
A		0001	1-26-72
LEARNSON			

FIRST USED ON OPTION/MODEL	QTY.	DESCRIPTION	PART NO.	ITEM NO.
PDP/8		PARTS LIST		
UNLESS OTHERWISE SPECIFIED DIMENSION IN INCHES TOLERANCES	DRN. Margaret 1-26-72	DATE 11-8-71	digital EQUIPMENT CORPORATION MAYNARD, MASSACHUSETTS	
DECIMALS .005 XX .02 X .1	CHK'D By 1-26-72	DATE 1-26-72		
ANGLES 10° 30'	ENG. J. Larson 1-26-72	DATE 1-26-72	TITLE INTERFACE TO I/O BUS	
REMOVE BURRS AND BREAK SHARP CORNERS SURFACE QUALITY	PROJ. ENG. J. Larson 1-26-72	DATE 1-26-72		
MATERIAL	NEXT HIGHER ASSY.	SIZE CODE NUMBER REV.		
FINISH	SCALE	D BS BD50-0-04 A		
	SHEET OF	DIST.		

This drawing and specifications, herein, are the property of Digital Equipment Corporation and shall not be reproduced or copied or used in whole or in part as the basis for the manufacture or sale of items without written permission.

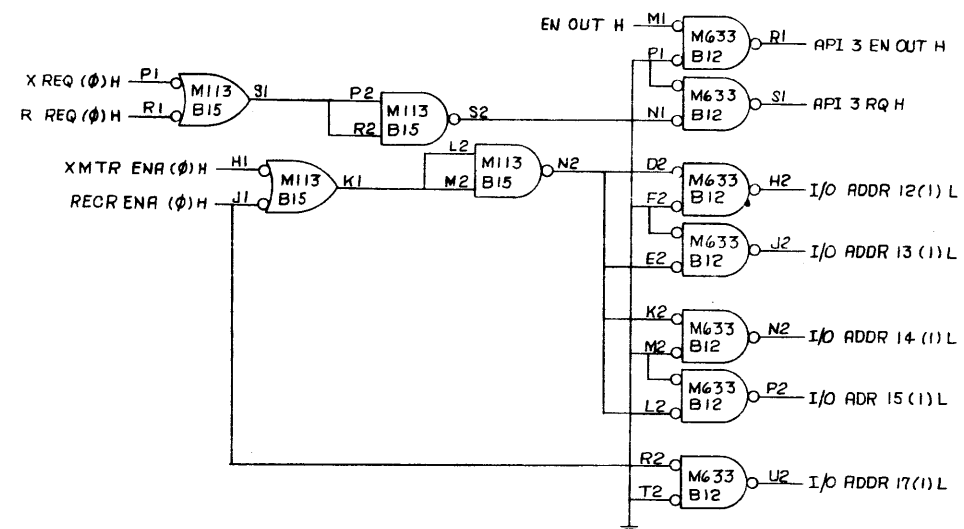
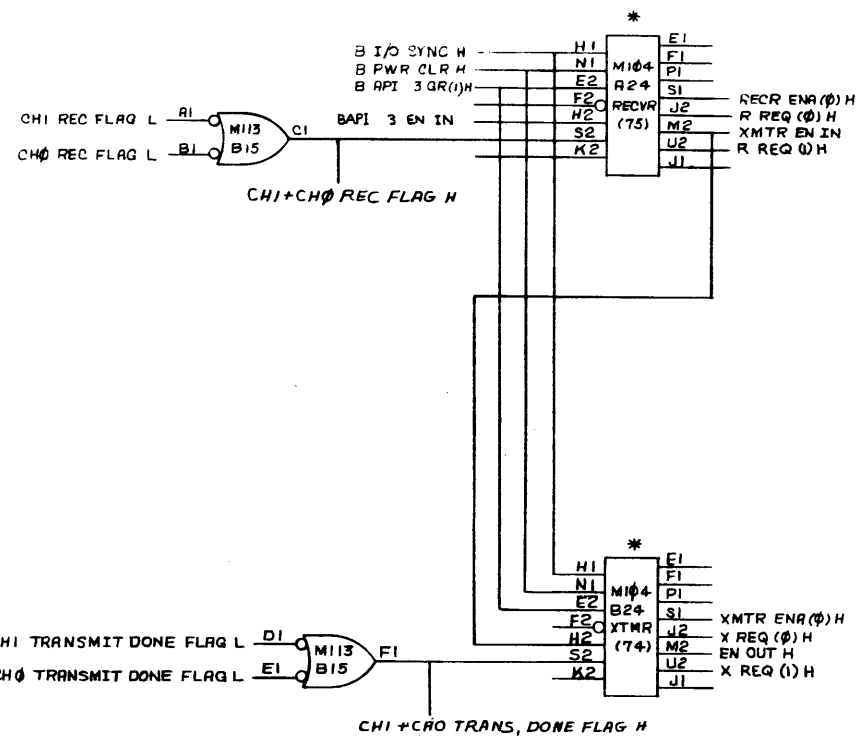

\*NOTE:  
 WHEN NOT USED WITH PDP-9 API REMOVE  
 THE M104'S IN SLOTS A24 AND B24  
 ADD:  
 B23E2-B23PI-B15U1  
 B15H1-B15J1-B15PI-B15RI-B15V1

REV.	CHANGE NO.	DATE	BY
1	00001	A	LEARSON

FIRST USED ON OPTION/MODEL	QTY.	DESCRIPTION	PART NO.	ITEM NO.
PDP/6				
PARTS LIST				
UNLESS OTHERWISE SPECIFIED DIMENSION IN INCHES TOLERANCES		DRN. Com'ly DATE 1-17-72	 digital EQUIPMENT CORPORATION MAYNARD MASSACHUSETTS	
DECIMALS ANGLES		CHK'D. DATE 1-26-72		
.XX - .005 ±0° 30'		ENG. DATE 1-26-72		
.X - .02		PROJ. ENG. DATE 1-26-72		
REMOVE BURRS AND BREAK SHARP CORNERS SURFACE QUALITY		PROJ. DATE 1-26-72	TITLE	
MATERIAL		NEXT HIGHER ASSY.	BD50-API	
FINISH		B-DD - FD50 - 1	(USED ONLY ON PDP9)	
SCALE		SHEET OF	SIZE CODE	NUMBER
SHEET OF		DIST.	BS	BD50-0-05
			REV.	A

This drawing and specifications, herein, are the property of Digital Equipment Corporation and shall not be reproduced or copied or used in whole or in part as the basis for the manufacture or sale of items without written permission.

DEVICE CODE SELECT JUMPER BOARD  
 M921 (SEE CHART BELOW)

PRINT SIG NAME PDF9 SIG NAME PDP8,8S, SIG NAME PDP8I,8L, SIG NAME

DS 0 (1) H	DS 1 (1) H	BMB 03 (0) H	
DS 1 (1) H	DS 2 (1) H	BMB 04 (0) H	
DS 2 (1) H	DS 3 (1) H	BMB 05 (0) H	
DS 3 (1) H	DS 4 (1) H	BMB 06 (0) H	
DS 4 (1) H	DS 5 (1) H	BMB 07 (0) H	
DS 5 (1) H		BMB 08 (0) H	
SEL 00 (1) L		BMB 03 (0) H	
SEL 00 (1) H		BMB 03 (1) H	
SEL 01 (1) L		BMB 04 (0) H	
SEL 01 (1) H		BMB 04 (1) H	
SEL 02 (1) L		BMB 05 (0) H	
SEL 02 (1) H		BMB 05 (1) H	
SEL 03 (1) L		BMB 06 (0) H	
SEL 03 (1) H		BMB 06 (1) H	
SEL 04 (1) L		BMB 07 (0) H	
SEL 04 (1) H		BMB 07 (1) H	
SEL 05 (1) L		BMB 08 (0) H	
SEL 05 (1) H		BMB 08 (1) H	
DATA BUS 00 (1) L	I/O BUS 10 (1) L	BAC 04 BUS L	AC 04 BUS L
DATA BUS 01 (1) L	I/O BUS 11 (1) L	BAC 05 BUS L	AC 05 BUS L
DATA BUS 02 (1) L	I/O BUS 12 (1) L	BAC 06 BUS L	AC 06 BUS L
DATA BUS 03 (1) L	I/O BUS 13 (1) L	BAC 07 BUS L	AC 07 BUS L
DATA BUS 04 (1) L	I/O BUS 14 (1) L	BAC 08 BUS L	AC 08 BUS L
DATA BUS 05 (1) L	I/O BUS 15 (1) L	BAC 09 BUS L	AC 09 BUS L
DATA BUS 06 (1) L	I/O BUS 16 (1) L	BAC 10 BUS L	AC 10 BUS L
DATA BUS 07 (1) L	I/O BUS 17 (1) L	BAC 11 BUS L	AC 11 BUS L
DATA OUT 00 (1) H		BAC 04 (1) H	
DATA OUT 01 (1) H		BAC 05 (1) H	
DATA OUT 02 (1) H		BAC 06 (1) H	
DATA OUT 03 (1) H		BAC 07 (1) H	
DATA OUT 04 (1) H		BAC 08 (1) H	
DATA OUT 05 (1) H		BAC 09 (1) H	
DATA OUT 06 (1) H		BAC 10 (1) H	
DATA OUT 07 (1) H		BAC 11 (1) H	
BAC 04 (1) L		BAC 04 (1) L	
BAC 05 (1) L		BAC 05 (1) L	
BAC 06 (1) L		BAC 06 (1) L	
BAC 07 (1) L		BAC 07 (1) L	
BAC 08 (1) L		BAC 08 (1) L	
BAC 09 (1) L		BAC 09 (1) L	
BAC 10 (1) L		BAC 10 (1) L	
BAC 11 (1) L		BAC 11 (1) L	
IOP 1 H	IOP 1 H	IOP 1 H	
IOP 2 H	IOP 2 H	IOP 2 H	
IOP 4 H	IOP 4 H	IOP 4 H	
BIOP 1 H			BIOP 1 H
BIOP 2 H			BIOP 2 H
BIOP 4 H			BIOP 4 H
PWR CLR H	I/O PWR CLR H	B INT H	
B PWR CLR H			B INT H
SKIP BUS L	SKIP BUS L	SKIP BUS L	SKIP BUS L
INT RQST BUS L	INT REQ BUS	INT RQST BUS L	INT RQST BUS L
RD RQ L	RD RQ L		
AC CLEAR CONT BUS L		AC CLEAR CONT BUS L	AC CLEAR CONT BUS L

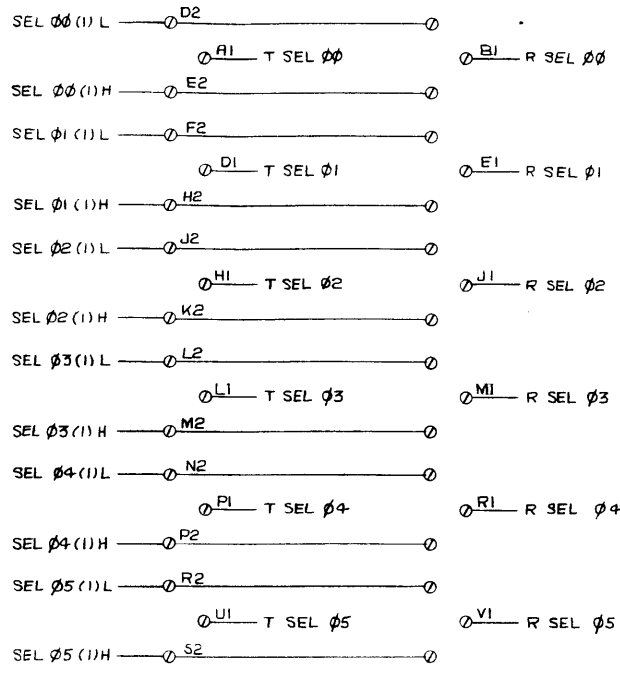

NOTE: WHEN USED TO REPLACE PDP-8 CONSOLE TTY GND ME17K AND ME17N AND REMOVE TTY CLK IN PDP-8

M921 JUMPER SELECTION CHART

JUMPERS TO BE PUT IN WHEN USED ON PDP-8, 8S, 8L, 8I							WHEN USED ON PDP9	
WHEN USED AS A CONSOLE TELEPRINTER REPLACEMENT			WHEN USED AS AN EXTRA DEVICE				WHEN USED AS AN EXTRA DEVICE	
CODE	TRANS 04	REC 03	TRANS 01	REC 02	TRANS 03	REC 02	TRANS 04	REC 01
PIN	TO	TO	TO	TO	TO	TO	TO	TO
D2	A1	B1						
E2			A1	B1	A1	B1		
F2	D1	E1	D1	E1	D1	E1	D1	E1
H2								
J2	H1	J1	H1	J1	H1	J1	H1	J1
K2								
L2		M1	L1	M1	L1	M1	L1	M1
M2	L1							
N2	P1		P1	R1			P1	R1
P2		R1			P1	R1		
R2	U1			V1		V1	U1	
S2		V1	U1		U1			V1

REV	
CHANGE NO.	
CHK	

FIRST USED ON OPTION/MODEL	QTY.	DESCRIPTION	PART NO.	ITEM NO.
PDP8		PARTS LIST		
UNLESS OTHERWISE SPECIFIED DIMENSION IN INCHES. TOLERANCES	DRN. Margaret Waughman	DATE 11-11-71	digital EQUIPMENT CORPORATION MAYNARD, MASSACHUSETTS	
DECIMALS .005	CHK'D J. Larson	DATE 1-26-72		
ANGLES ±0° 30'	ENG. J. Larson	DATE 1-26-72		
XXX - .02	PROJ. ENG. J. Larson	DATE 1-26-72		
REMOVE BURRS AND BREAK SHARP CORNERS SURFACE QUALITY	PROD. W. Reed	DATE 1-26-72	TITLE I/O T SELECTION	
MATERIAL	NEXT HIGHER ASSY.	R-DD-BD50-0	SIZE CODE	NUMBER
FINISH	SCALE	D BS BD50 - 0 - 06		REV.
	SHEET	OF	DIST.	

This drawing and specifications, herein, are the property of Digital Equipment Corporation and shall not be reproduced or copied or used in whole or in part as the basis for the manufacture or sale of items without written permission.

REV 27 - C - 0508 D 2

D

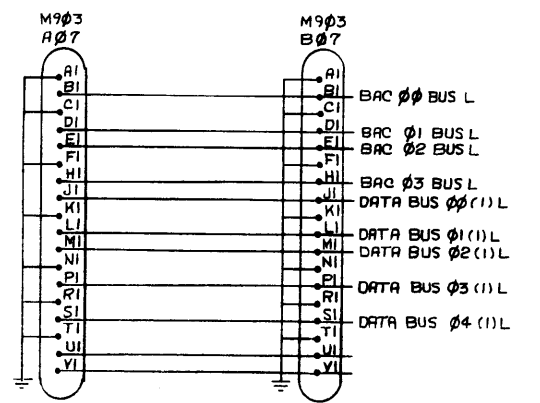
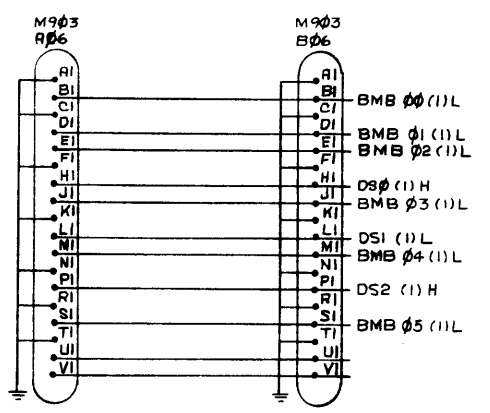
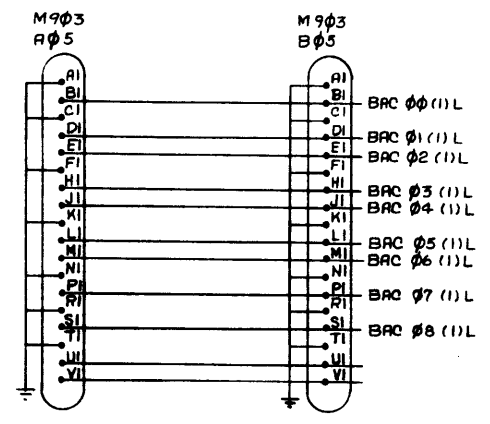

C

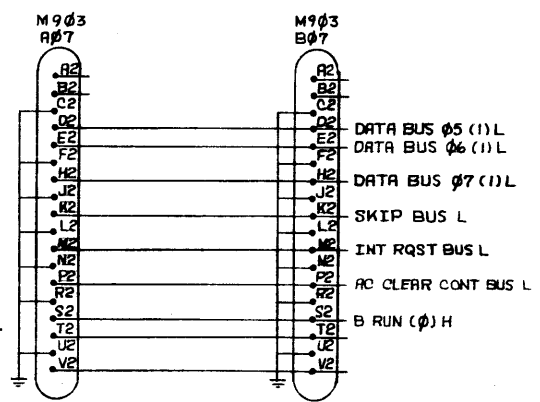
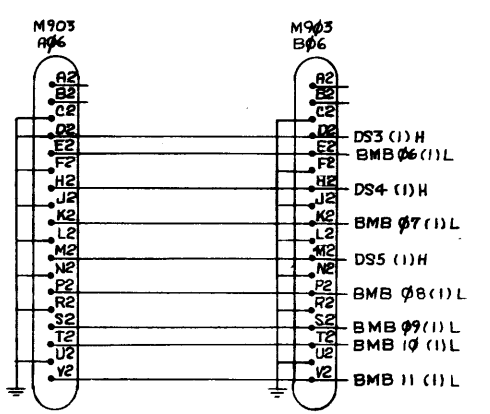
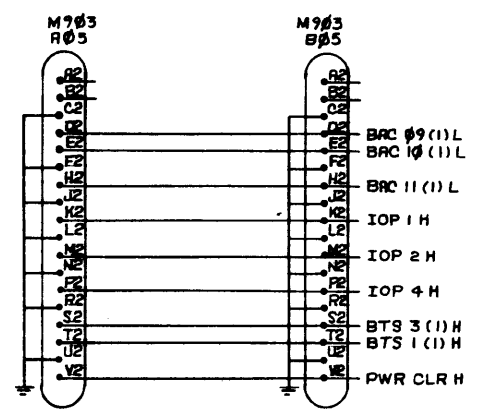

B

A

REVISIONS	REV
CHANGE NO.	
CHK	

DEC FORM NO DRD 100-A

FIRST USED ON OPTION/MODEL	QTY.	DESCRIPTION	PART NO.	ITEM NO.
PDP/8				
PARTS LIST				
UNLESS OTHERWISE SPECIFIED DIMENSION IN INCHES TOLERANCES	DRN. <i>Malcolm Daughinais</i>	DATE 11-11-71	 <b>DIGITAL EQUIPMENT CORPORATION</b> <small>MAYFORD, MASSACHUSETTS</small>	
DECIMALS	CHK'D. <i>J. Johnson</i>	DATE 1-26-72		
ANGLES	ENG. <i>J. Johnson</i>	DATE 1-26-72		
.XXX = .000 .XX = .02 .X = .1	PROJ. ENG. <i>J. Johnson</i>	DATE 1-24-72		
REMOVE BURRS AND BREAK SHARP CORNERS SURFACE QUALITY	PROD. <i>J. Johnson</i>	DATE 1-24-72	<b>TITLE</b> <b>TO NEG BUS</b> <b>I/O BUS CONNECTORS</b>	
MATERIAL	NEXT HIGHER ASSY.			
FINISH	B-DD-BD50 - 0	SCALE	SIZE CODE	NUMBER
	SHEET	OF	DIC	BD50 - 0 - 07
	DIST.			REV.

REV 27 - C - 0508 D 2

B

A

This drawing and specifications, herein, are the property of Digital Equipment Corporation and shall not be reproduced or copied or used in whole or in part as the basis for the manufacture or sale of items without written permission.

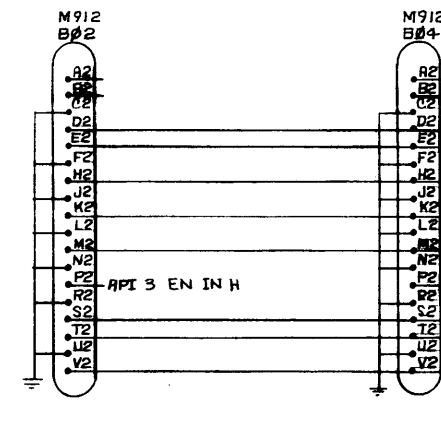
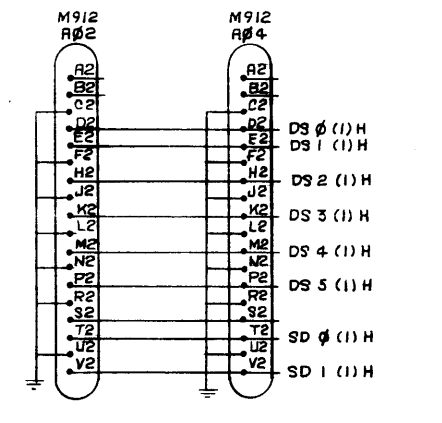
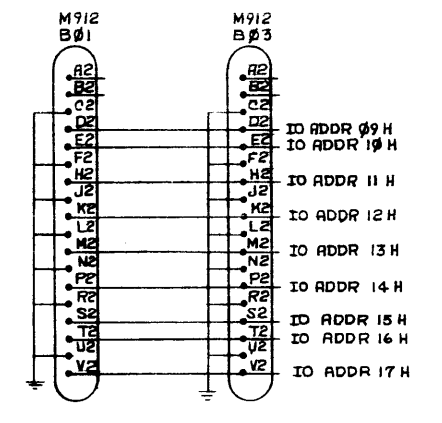
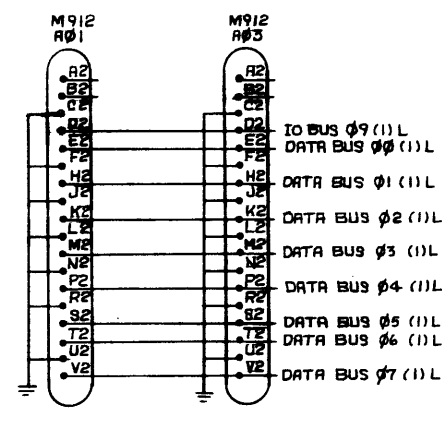
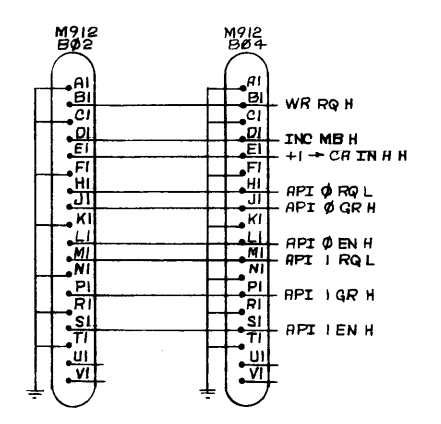
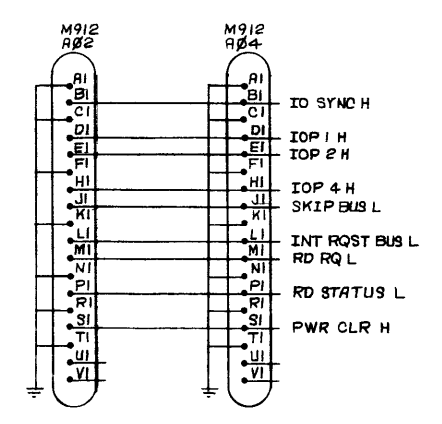
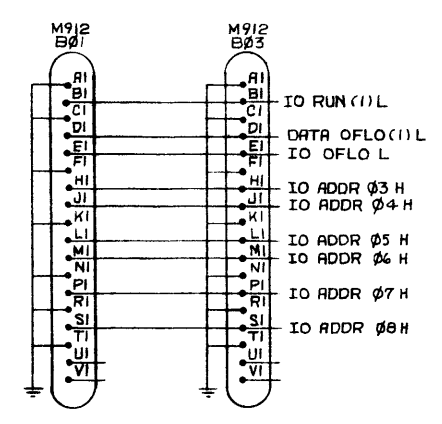
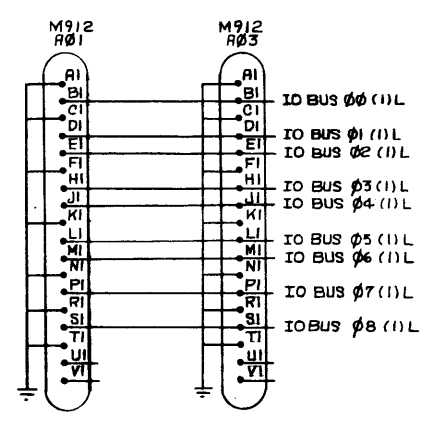

REV.	
CHANGE NO.	
CHK	

FIRST USED ON OPTION/MODEL	QTY.	DESCRIPTION	PART NO.	ITEM NO.
PDP/8		PARTS LIST		
UNLESS OTHERWISE SPECIFIED DIMENSION IN INCHES TOLERANCES	DRN: <i>W. Morgan</i> DATE: 11-15-71	 digital EQUIPMENT CORPORATION MAYNARD MASSACHUSETTS TITLE: (PDP-9) I/O BUS CABLE		
DECIMALS	CHK'D: <i>J. O'Sullivan</i> DATE: 1-26-72			
ANGLES	ENG: <i>J. O'Sullivan</i> DATE: 1-26-72			
XXX - .005	PROJ. ENG. DATE: 1-26-72			
.XX - .02	DATE: 1-26-72			
X - .1	DATE: 1-26-72			
REMOVE BURRS AND BREAK SHARP CORNERS SURFACE QUALITY	PROD: <i>W. Morgan</i> DATE: 1-26-72			
MATERIAL	NEXT HIGHER ASSY.	SIZE CODE	NUMBER	REV.
	B-DD-0050-0	DIC	BD50-0-08	
FINISH	SCALE	SHEET	OF	DIST.

This drawing and specifications, herein, are the property of Digital Equipment Corporation and shall not be reproduced or copied or used in whole or in part as the basis for the manufacture or sale of items without written permission.

60-0-0908 2

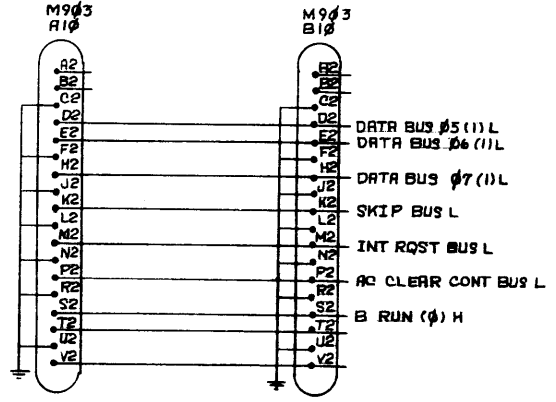
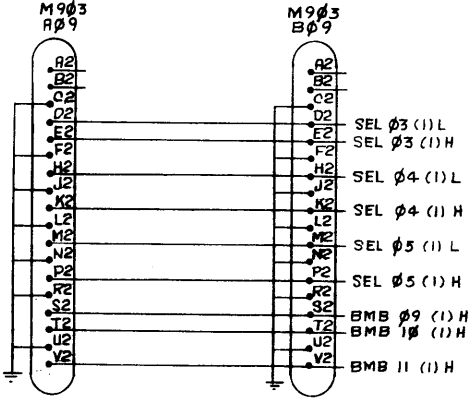
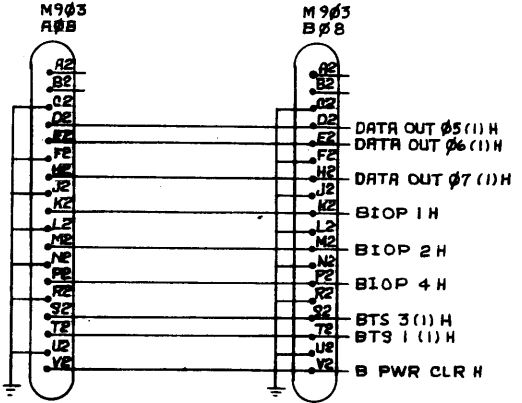
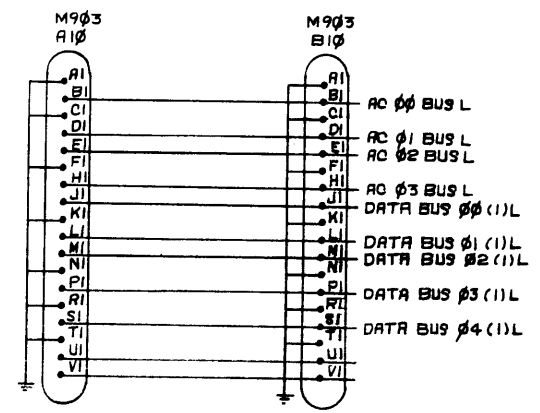
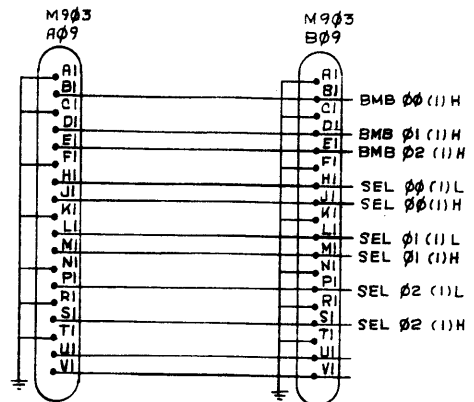
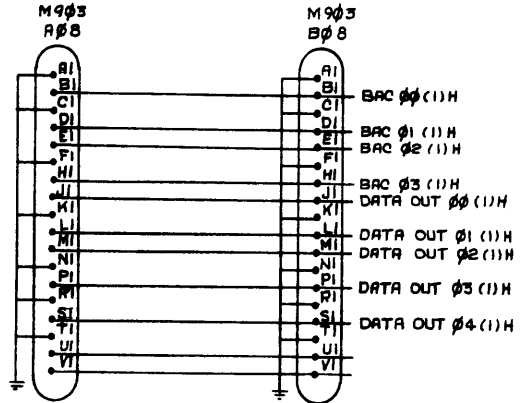

REVISIONS	REV
CHANGE NO.	
CHK	

FIRST USED ON OPTION/MODEL	QTY.	DESCRIPTION	PART NO.	ITEM NO.
PDP/8				
UNLESS OTHERWISE SPECIFIED		PARTS LIST		
DIMENSION IN INCHES		digital EQUIPMENT CORPORATION		
TOLERANCES		MAYNARD MASSACHUSETTS		
DECIMALS	ANGLES	TITLE		
.XXX - .000	10° 30'	I/O BUS CONNECTION TO POS BUS		
.XX - .02		D I C B D 5 0 - 0 - 0 9		
.X - .1		REV.		
REMOVE BURRS AND BREAK SHARP CORNERS SURFACE QUALITY		NEXT HIGHER ASSY.		
MATERIAL		SHEET 2 OF 2		
FINISH		DIST.		

D I C B D 5 0 - 0 - 0 9

DRWG NO	REV LTR
K - WL - BD5 $\phi$ - $\phi$ - 1 $\phi$	C

REVISIONS			
REV LTR	ECO NO	DATE	ENG
A	00001	2-14-72	<i>[Signature]</i>
B	00003	6-26-72	<i>[Signature]</i>
C	00005	12-15-72	<i>[Signature]</i>

DRAWN <i>Margaret</i> <i>Kauphman</i>	DATE 11-18-71	 <b>digital</b> EQUIPMENT CORPORATION MAYNARD, MASSACHUSETTS	TITLE ASYNCHRONOUS SERIAL LINE INTERFACE		
CHECKED <i>[Signature]</i>	DATE 1/24/72		FOR TAPE #      FILE #		
ENG <i>[Signature]</i>	DATE 1/26/72		ASSY NO D - AD - 7008716-0-0	SIZE K	CODE WL
PROJ. ENG <i>[Signature]</i>	DATE 1-26-72		DWG. NO. BD5 $\phi$ - $\phi$ - 1 $\phi$	REV LTR C	
PROD <i>[Signature]</i>	DATE 1-26-72	SCALE    //    SHEET    OF    DIST.			

This drawing and specifications, herein, are the property of Digital Equipment Corporation and shall not be reproduced or copied or used in whole or in part as the basis for the manufacture or sale of items without written permission.

**DIGITAL EQUIPMENT CORPORATION**  
MAYNARD, MASSACHUSETTS

**ENGINEERING SPECIFICATION**

DATE 12/14/71

TITLE BD50 Asynchronous Serial Line Interface

REVISIONS

REV	DESCRIPTION	CHG NO	ORIG	DATE	APPD BY	DATE
A	CHANGE PER ECO	BD50-00003	LEARSON	6/72	<i>J. Learson</i>	6-29-72

ENG <i>J. Learson</i>	APPD <i>J. Learson</i>	SIZE <b>A</b>	CODE SP	NUMBER BD50-0-11	REV A
-----------------------	------------------------	---------------	---------	------------------	-------

DEC FORM NO. DRA 107

SHEET 1 OF 7

**ENGINEERING SPECIFICATION**

**digital**

CONTINUATION SHEET

TITLE BD50 Asynchronous Serial Line Interface

Description:

The BD50 is a self-contained asynchronous serial line interface which can accomodate up to two channels. It is directly plug compatible to the I/O Bus system of either the PDP-8 family (either positive or negative bus), the PDP-9, or the PDP-9/L. This device expands the machines communications faculty to accomodate two devices interfacing with 20 ma current loop or two parallel LA30's (DEC WRITER) or any combination of each. The BD50 can also interface EIA-LEVEL operated device such as a high speed asynchronous modem which meet the requirements of EIA SPEC RS232-C.

The BD50 is full duplex.

Each channel of the BD50 uses two variable clocks; One for transmitting and the other for receiving. This gives the user the added capability of transmitting and receiving data using a wide range of baud rates.

The BD50 uses the program interrupt and skip facilities of a computer and when used on a PDP-9, has the option of using API if the PDP-9 is so equipped. Because of the echo function of the PDP-9, the BD50 can not be used to replace the console teleprinter.

IOT's on either the PDP-9, PDP-9L or family of 8 are completely jumper selectable. The IOT codes given are recommended codes. Any convenient code can be used.

Note: The PDP-9 and PDP-9/L requires hardware echo back for the console teleprinter; the parallel LA30 cannot be used with the BD50 as a console teleprinter..

SIZE <b>A</b>	CODE SP	NUMBER BD50-0-11	REV A
---------------	---------	------------------	-------

DEC FORM NO DEC 16-(381)-1022-N370  
DRA 108

SHEET 2 OF 7



# ENGINEERING SPECIFICATION

CONTINUATION SHEET

TITLE BD50 Asynchronous Serial Line Interface

## 1.0 SPECIFICATIONS

### a. Mechanical

Logic Panel one 1943  
 Connector Blocks 6-H 803  
 Dimensions 19"w., 5<sup>3</sup>/<sub>16</sub>"h., 14"d.

### b. ELECTRICAL

AC input power 115 V AC, 60 Hz  
 230 V AC, 50Hz

Power Supply H 716  
 +5V @ 4 amps.  
 -15V @ 1.5 amps.

Module type M series

### c. OPERATIONAL

Capacity two channels

Line Driving 20 Ma current loop 25 feet\*\*  
 EIA Levels 25 feet

Transfer Rates 110 to 2400 BAUD

## 2.0 INSTALLATION

TYPE OF MACHINE	TYPE OF CABLES
PDP-8; or PDP-8/S	BC08C* 6
PDP-8/L; or PDP-8I	BC08A* 6
PDP-9	BC09C* 5

\*6 foot length will be shipped unless specified differently by customer.

\*\*Will drive up to 2000 feet depending on Baud rate and cable characteristic

SIZE	CODE	NUMBER	REV
A	SP	BD50-0-11	A

# ENGINEERING SPECIFICATION

CONTINUATION SHEET

TITLE BD50 Asynchronous Serial Line Interface

## 2.1 INTERFACING CABLES FOR:

20 MA CL	7008519
EIA RS232C	BC01J-25 (VT05)
EIA RS232C	BC01A-25

## 2.2 INTERFACING

Interfacing, to either 5 or 8 Bit code.

### a. M706

Pin Connections for 5 or 8 bit code:

5 bit code AM2 to AJ2  
 AR1 to Ground

8 bit: AM2 to AR1  
 AJ2 to AK1

Pin Connections for stop time:

1.0 units - BP2 to BT2  
 BR2 to BU2

1.5 Units BP2 to BS1  
 BR2 to BU2

2.0 Units BP2 to BT2  
 BR2 to BV2

### b. M707

Pin Connections for 5 or 8 bit code:

5 Bit - AK1 to AJ1

8 Bit - AK1 to AK2

Pin connections for stop time:

1.0 units - BN2 to BR2

1.5 units - BN2 to BP1

2.0 units - BN2 to BN1

SIZE	CODE	NUMBER	REV
A	SP	BD50-0-11	A

# ENGINEERING SPECIFICATION

CONTINUATION SHEET

TITLE BD50 Asynchronous Serial Line Interface

### 3.0 BD50 VARIATIONS

BD50-AA	115 V AC; 8 Pos Bus
BD50-AB	230 V AC; 8 Pos Bus
BD50-BA	115 V AC; 8 Neg. Bus
BD50-BB	230 V AC; 8 Neg. Bus
BD50-CA	115 V AC; 9 Bus
BD50-CB	230 V AC; 9 Bus

### 4.0 PROGRAMMING

#### 4.1 PDP-9

The PDP-9 IOT instruction format is shown in Fig. 4.1

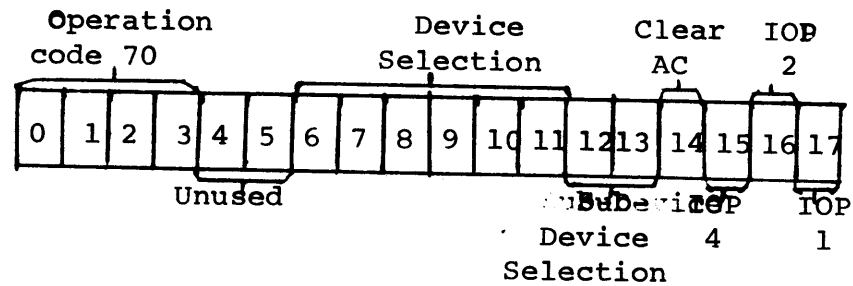

Fig. 4.1

When LT19 device codes are used, 40 and 41, the sub-device selection bits are decoded as follows:

Bits 13	Bits 12	Channel
0	0	0
1	0	1

When any other device code is used the sub device selection bits are not decoded.

SIZE	CODE	NUMBER	REV
A	SP	BD50-0-11	A

# ENGINEERING SPECIFICATION

CONTINUATION SHEET

TITLE BD50 Asynchronous Serial Line Interface

### RECOMMENDED CODES

### FUNCTION

Channel 0

704001

CH0 skip if transmitter flag is set.

704002

Clear CH0 transmitter flag.

704004

Loads CH0 transmitter and sends character.

704101

Skip if CH0 receiver flag is set.

704102

Reads contents of CH0 receiver module and clears flag.

Channel 1

704021

CH1 skip if transmitter flag is set.

704022

Clears CH1 transmitter flag.

704024

Loads CH1 transmitter and sends character.

SIZE	CODE	NUMBER	REV
A	SP	BD50-0-11	A

# ENGINEERING SPECIFICATION

000000

CONTINUATION SHEET

TITLE BD50 Asynchronous Serial Line Interface

RECOMMENDED CODES	FUNCTION
Channel 1	
<u>704121</u>	Skip if CH1 receiver flag is set.
<u>704122</u>	Reads contents of CH1 receiver module and clears flag.
4.2 PDP-8 Family	
When CH0 is used as a console teleprinter replacement use standard TTY IOT's.	

**I/O DEVICE**

RECOMMENDED CODES	FUNCTION
Channel 0	
<del>6411</del>	CH0 skip if transmitter flag is set.
6412	CH0 Clear transmitter flag.
6414	Loads CH0 transmitter and sends character.
6401	CH0 skip if receiver flag is set.
6402	Clear CH0 receiver module.
6404	Reads CH0 receiver module.
Channel 1	
6421	CH1 skip if receiver flag is set.
6422	Clear CH1 receiver flag.
6424	Reads CH1 receiver module.
6431	CH1 skip if transmitter flag is set.
6432	CH1 clear transmitter flag.
6434	Loads CH1 transmitter module.

SIZE <b>A</b>	CODE SP	NUMBER BD50-0-11	REV <b>A</b>
------------------	------------	---------------------	-----------------

**DIGITAL EQUIPMENT CORPORATION  
MAYNARD, MASSACHUSETTS**

**ENGINEERING SPECIFICATION**

DATE 1/26/72

TITLE BD50 ACCEPTANCE

REVISIONS

REV	DESCRIPTION	CHG NO	ORIG	DATE	APPD BY	DATE

**SCOPE:**

To Define the criteria necessary for acceptance of the BD50.

**PDP-9:**

**Acceptance Test:**

LT19 Diagnostic, Maindec-09-D8cc, must run successfully.  
In addition, the following documentation list must be complete.

- a. 1 set of BD50 prints
- b. Program tape (LT19 Diagnostic)
- c. Write up of LT19 diagnostic

**PDP-8;8I,8L**

**Acceptance Test:**

LT08 Diagnostic, Maindec 828, must run successfully.  
In addition, the following documentation list must be complete.

- a. 1 set of BD50 prints
- b. Program Tape (LT08 Diagnostic)
- c. Write up of LT08 diagnostic.

This drawing and specifications, herein, are the property of Digital Equipment Corporation and shall not be reproduced or copied or used in whole or in part as the basis for the manufacture or sale of items without written permission.

ENG <i>John D. Farnsworth</i>	APPD <i>W. L. Larson</i>	SIZE A	CODE SP	NUMBER BD50-0-12	REV
----------------------------------	-----------------------------	-----------	------------	---------------------	-----

This drawing and specifications, herein, are the property of Digital Equipment Corporation and shall not be reproduced or copied or used in whole or in part as the basis for the manufacture or sale of items without written permission.

LEGEND	
NUMBER	"A" DIM
BCØIJ-1Ø	1Ø" ± 2"
BCØIJ-25	25" ± 5"

WIRE TABLE				
ITEM NO.	DESCRIPTION	FROM CONNECTION	TO CONNECTION	REMARKS
3	BLK	PI-7	P2-5	
3	GRN	PI-2	P2-2	
3	RED	PI-3	P2-3	
3	BRN	PI-1	P2-5	
10 22		PI-5	PI-6	JUMPER
10 22		PI-6	PI-8	JUMPER
3	WHT	PI-5	P2-1	

NOTES:  
 1. ALL WIRES AND JUMPERS IN PI ARE TO BE INSULATED WITH A .25 INCH PIECE OF TUBING (ITEM #5).  
 2. APPLY TAPE (ITEM #9) BETWEEN CABLE (ITEM #3) AND BOARD (ITEM #4), ALSO BETWEEN CLAMP (ITEM #8) AND CABLE.

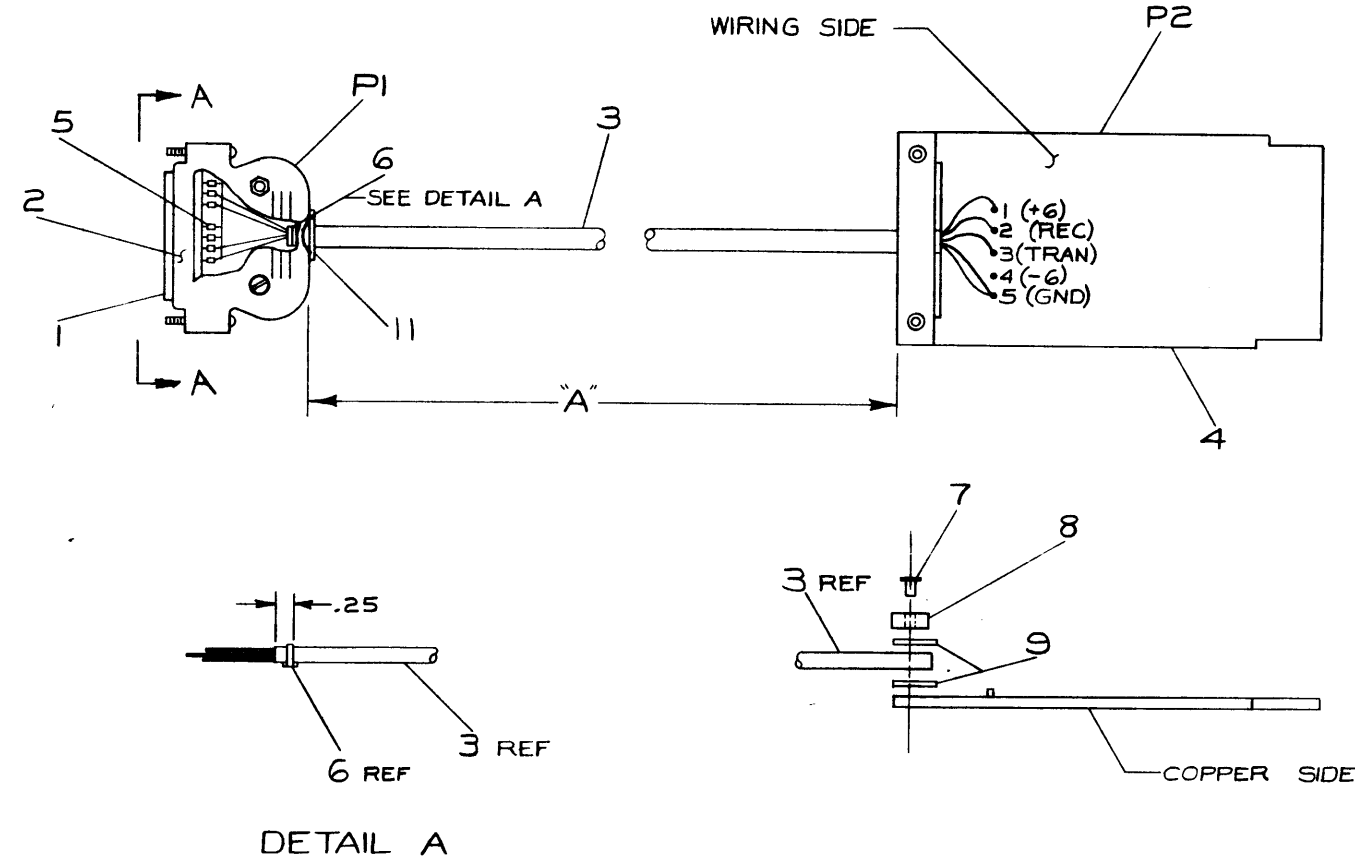
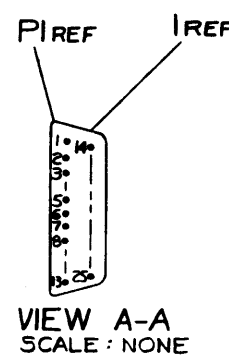

QTY.	DESCRIPTION	PART NO.	ITEM NO.
1	GROMMET	9007668	11
A/R	22 AWG BUS WIRE	9107560-01	10
A/R	TAPE, #4032, .03 THK x .50W	9007834	9
1	CABLE CLAMP	1202704	8
2	EYELET, #6S-4-7, STIMPSON	9006732	7
1	TIE WRAP, PANDUIT #SST-1B	9007031	6
A/R	HIGH SHRINK TUBING, WHT, .12 IN	9107255	5
1	EIA LEVEL CONVERTER	M850	4
A/R	CABLE, BELDON, 5 COND	9107630	3
1	CANNON PLUG HOOD #DB51226-1	1205885	2
1	CANNON CONNECTOR DB-19604-433 (DBM25S)	1204975	1

FIRST USED ON OPTION / MODEL  
LT37

DO NOT SCALE DRAWING  
UNLESS OTHERWISE SPECIFIED  
DIMENSION IN INCHES  
TOLERANCES

DATE: 5/1/70  
 DATE: 5-20-70  
 DATE: 5/2/70  
 DATE: 10/1/70  
 DATE: 2/20/70

digital EQUIPMENT CORPORATION  
MAYNARD, MASSACHUSETTS

TITLE  
LEVEL CONVERTER (BI POLAR)

SIZE/CODE: DIA BCØIJ-Ø-Ø  
NUMBER: 11  
REV: A

SCALE: NONE  
SHEET: 1 OF 1

REV.	CHANGE NO.

This drawing and specifications, herein, are the property of Digital Equipment Corporation and shall not be reproduced or copied or used in whole or in part as the basis for the manufacture or sale of items without written permission.

LEGEND		
NUMBER	DIM 'A'	TOLERANCE
BC01A-5	5 FT	± 2 IN
BC01A-10	10 FT	± 3 IN
BC01A-15	15 FT	± 4 IN
BC01A-20	20 FT	± 5 IN
BC01A-25	25 FT	± 6 IN
BC01A-30	30 FT	± 7 IN
BC01A-35	35 FT	± 8 IN
BC01A-40	40 FT	± 10 IN
BC01A-45	45 FT	± 11 IN
BC01A-50	50 FT	± 12 IN

WIRE TABLE						
ITEM NO	DESCRIPTION	FROM		TO		WITH
		CONNECTION	WITH	CONNECTION	WITH	
3	#22 BLK	P1-1	S-SOLDER	P2-5	SOLDER	
3	#22 RED	P1-2	S-SOLDER	P2-3	SOLDER	
3	#22 GRN	P1-3	S-SOLDER	P2-2	SOLDER	
3	#22 ORN	P1-7	S-SOLDER	P2-3	SOLDER	
3	#22 WHT	P1-20	S-SOLDER	P2-1	SOLDER	

**NOTES:**

- EACH SOLDERED CONNECTION ON P1 SHALL BE INSULATED WITH A 1/4 INCH PIECE OF HY-SHRINK TUBING (#5)
- APPLY TAPE (#9) BETWEEN CABLE (#3) AND BOARD (#4) THEN SOLDER. ASSEMBLE CLAMP (#8) & EYELETS (#7) TO BOARD AFTER SOLDERING.
- ~~VARIATIONS AND LENGTHS SHOWN IN LEGEND ARE STANDARD OTHER THAN STANDARD. VARIATIONS WILL BE SPECIFIED BY ALPHANUMERIC DESIGNATION FOR LENGTHS OTHER THAN FOOT INCREMENTS FROM ONE (1) FOOT THRU NINE (9) FEET, ELEVEN (11) INCHES.~~
  - ~~A-1" = 0-7"~~
  - ~~B-2" = 1-2"~~
  - ~~C-3" = 1-3"~~
  - ~~D-4" = 1-10"~~
  - ~~E-5" = 1-11"~~
  - ~~F-6" = 1-12"~~

~~EXAMPLE: BC01A-50 = 5'0" LENGTHS WILL BE IN FOOT INCREMENTS FROM TEN (10) FEET ON AND WILL BE SPECIFIED BY THE CORRESPONDING NUMERICAL DESIGNATION. EXAMPLE: BC01A-11 = 11 FEET THE TOLERANCE ON DIMENSION 'A' WILL BE ± 2% OF THE FOOT INCREMENT.~~

- CABLE TO BE CUT TO DIM 'A' + 3 INCHES

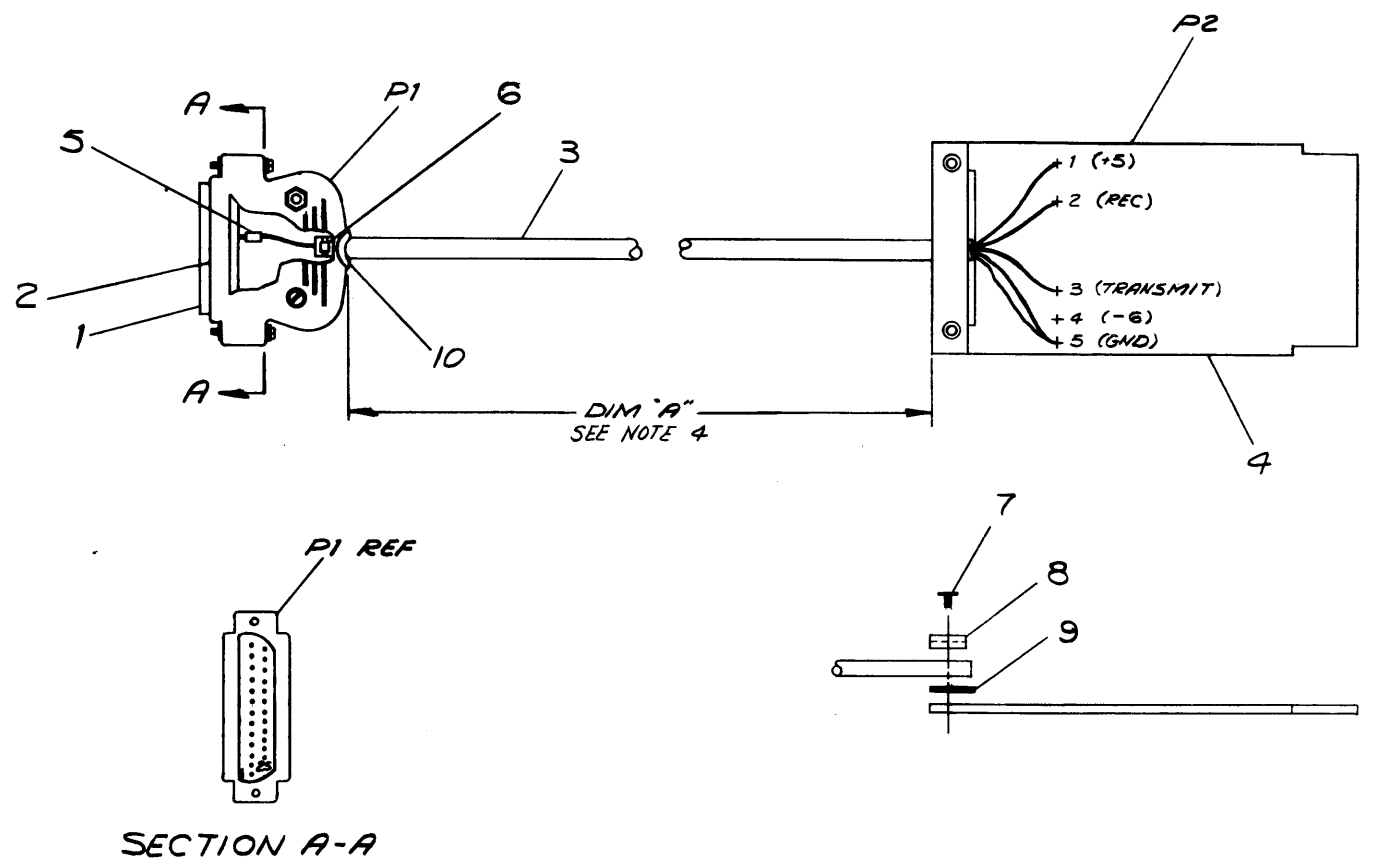

SECTION A-A

QTY.	DESCRIPTION	PART NO.	ITEM NO.
1	GROMMET # 809 A.I.R.	9007668	10
A/R	TAPE #4032 1/2 X 1 3/4 LG (3M CO)	9007839-0-0	9
1	CABLE CLAMP	1202704	8
2	EYELET #GS-9-7 STIMPSON	9006732	7
1	TIE WRAP PANDUIT #SST-1B	9007031	6
4	HEAT SHRINK TUBING 1/8 DIA	9107255	5
1	M850 CABLE CONN	M850	4
A/R	CABLE, BELDEN 5 COND	9107680	3
1	PLUG CINCH HOOD #DB5122G-1	1205885	2
1	PLUG CINCH DB-25 P	1205886	1

REV.	CHG. NO.	REV.
A	BC01A-00001	A
B	BC01A-00003	B

FIRST USED ON OPTION/MODEL: **BC01A**

DO NOT SCALE DRAWING

UNLESS OTHERWISE SPECIFIED DIMENSION IN INCHES

TOLERANCES: DECIMALS ± .005, FRACTIONS ± 1/64, ANGLES ± 0°30'

FINAL SURFACE QUALITY: REMOVE BURRS AND BREAK SHARP CORNERS

MATERIAL: \_\_\_\_\_

FINISH: \_\_\_\_\_

DRN: [Signature] DATE: 9-5-67

CHK'D: [Signature] DATE: 9/1/67

PROJ. ENG: [Signature] DATE: 8/21/67

PROJ. DATE: 8/21/67

NEXT HIGHER ASSY: \_\_\_\_\_

SCALE: \_\_\_\_\_

SHEET: 1 OF 1

digital EQUIPMENT CORPORATION

TITLE: **LEVEL CONVERTER (BI POLAR)**

SIZE CODE: D IA BC01A-0-0

NUMBER: \_\_\_\_\_

REV: B

This drawing and specifications, herein, are the property of Digital Equipment Corporation and shall not be reproduced or copied or used in whole or in part on the basis for the manufacture or sale of items without written permission.

- NOTES:**
1. CONNECTIONS ON ITEM NUMBER 1 & 2 TO BE LOCATED AND SOLDERED AT MINIMUM PRACTICAL HEIGHT ABOVE BLOCKS.
  2. ALL CONNECTOR BLOCKS TO BE GROUNDED TO GROUND LUGS AS SHOWN, 2 PLACES.
  3. USE YELLOW WIRE (ITEM #4) FOR MACHINE WRAPPED AND BLUE WIRE (ITEM #5) FOR HAND WRAPPED WIRING.

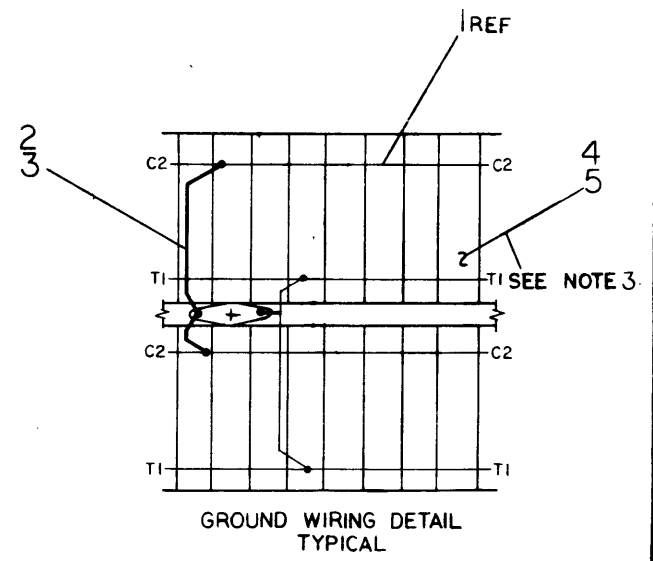
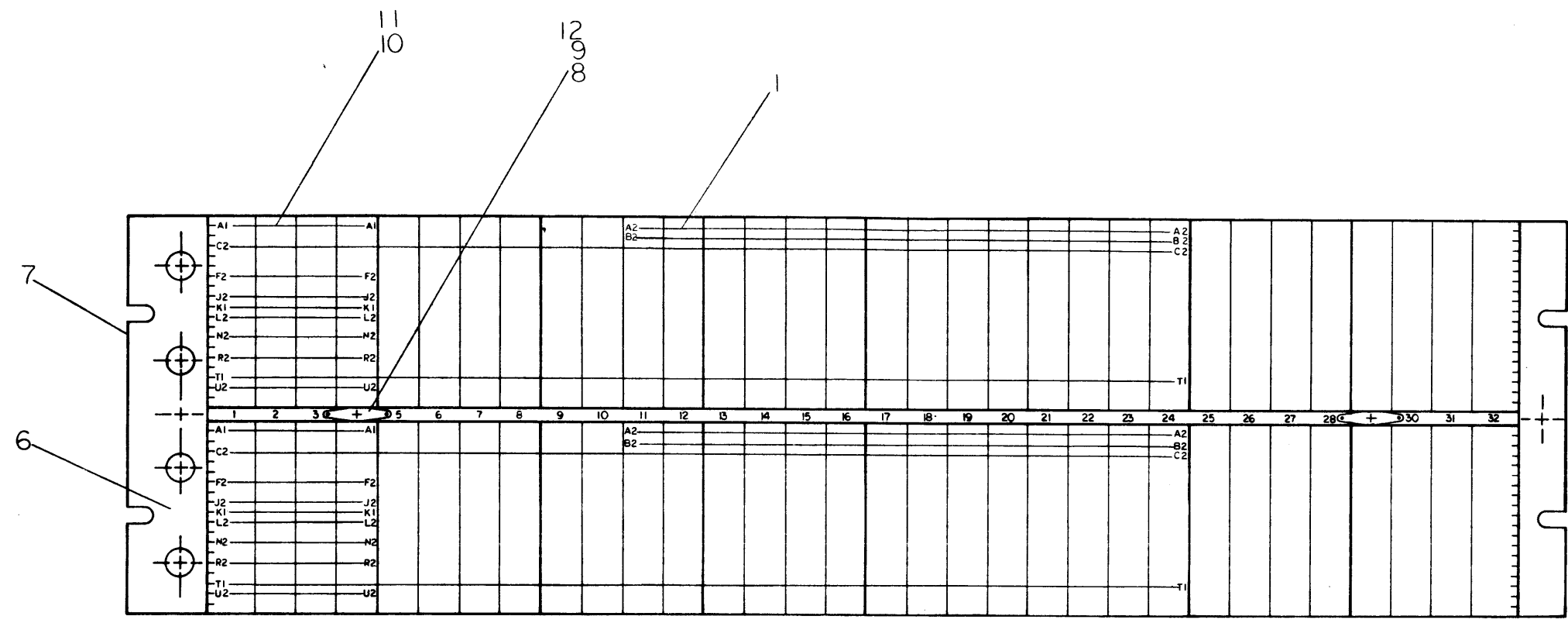

REV.	
CHG	
NO.	

REV. NO.	ITEM NO.	PART NO.	DESCRIPTION	QTY.	FIRST USED ON OPTION/MODEL
			PDP/8		
PARTS LIST					
digital EQUIPMENT CORPORATION MAYNARD, MASSACHUSETTS					
TITLE <b>WIRED ASS'Y</b>					
MATERIAL MEXD HIGHER ASSY					
B-DD-BD50 - 0					
FINISH SCALE NONE					
SHEET 1 OF 1					
DWT. DIST. D AD 7008716-0-0					

REV. 00-9128002-000

DIGITAL EQUIPMENT CORPORATION MAYNARD, MASSACHUSETTS					QUANTITY / VARIATION																
PARTS LIST																					
MADE BY M. DAUPHINAIS		CHECKED <i>J. Johnson</i>		SECTION																	
DATE 11/16/71		DATE 1-26-72		ISSUED SECT.																	
ENG <i>J. Johnson</i>		PROD <i>J. Keel</i>																			
DATE 1-26-72		DATE 1-26-72																			
ITEM NO.	DWG NO. / PART NO.	DESCRIPTION																			
1	1205541	BUS STRIP				A/R															
2	9107560-1	22 AWG BUS WIRE				A/R															
3	9107265	#22 TUBING, TEFLON, WHITE				A/R															
4	9105740-5	30 AWG SOLID TEF INS. WIRE, YEL				A/R															
5	9105740-7	30 AWG SOLID TEF INS. WIRE, BLU				A/R															
6	A-DC-7406371-0-0	LOGIC FRAME DECALS				A/R															
7	D-AD-5302483-0-0	1943 CASTING W/PINS				1															
8	9006634	WASH INT TOOTH LOCK #8				6															
9	9007597	TERM #2116-08-00 SHAKEPROOF				3															
10	1205348	288 PIN CONN. BLOCK H803				6															
11	9006120	SCR, FIL HD POZIDRIVE 8-32 X 5/8				12															
12	9006035-1	SCR, PHL HD PAN 8-32 X 1/4 SST				3															
REF	K-WL-BD50-0-11	WIRE LIST																			
TITLE					ASSY NO.					SIZE CODE		NUMBER			REV.		ECO NO.				
WIRED ASSY					D-UA-BD50-0-0					A PL		7008716-0-0									
					SHEET 1 OF 1					DIST.											